

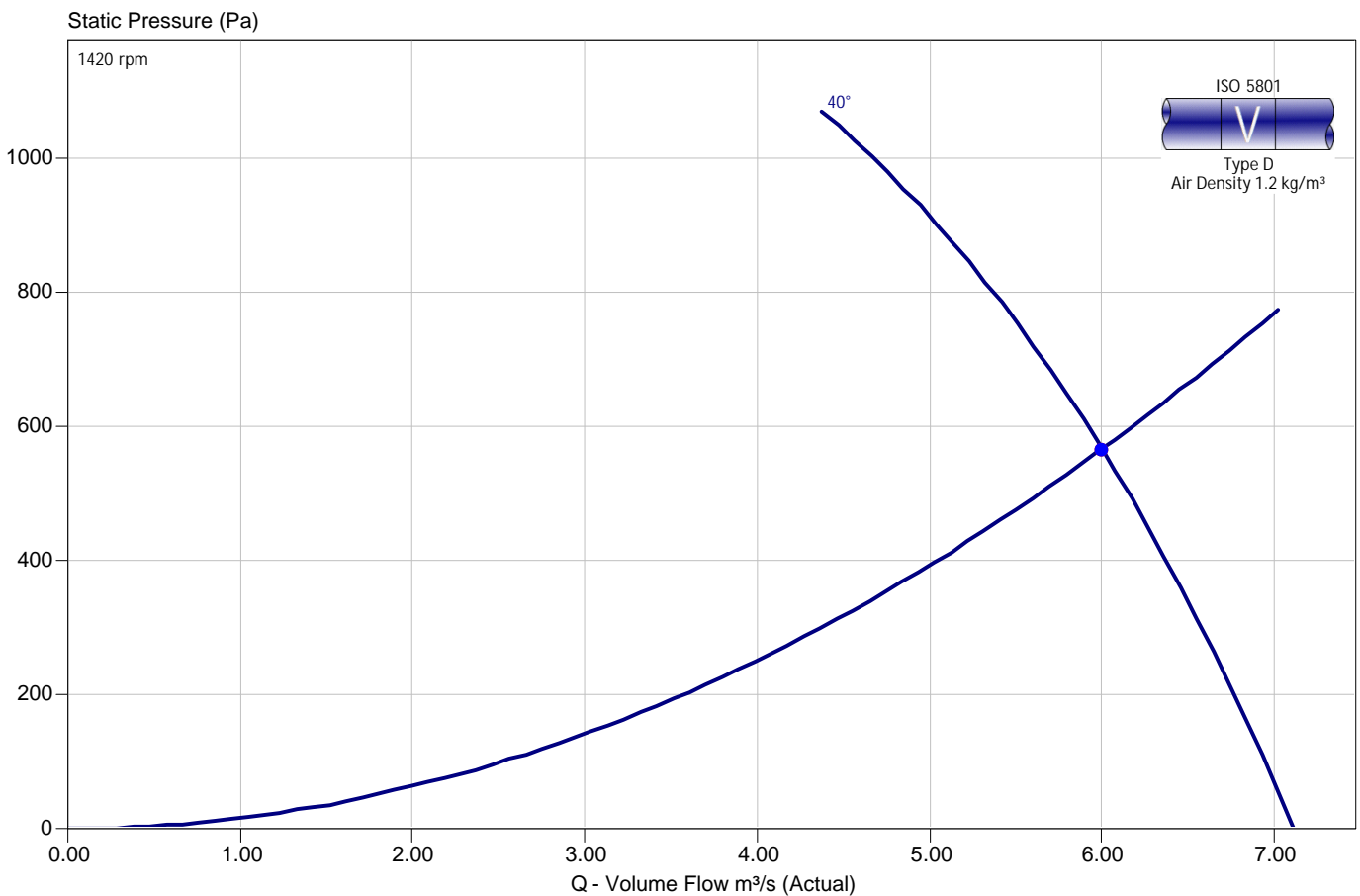

Quotation Number	:	Project Code	:
Project Name	:	Customer	:
Item Reference:	:	Date:	: Thursday, November 21, 2024
		Fan Code	: 63-3MaXfan2/25/4/9/40/32

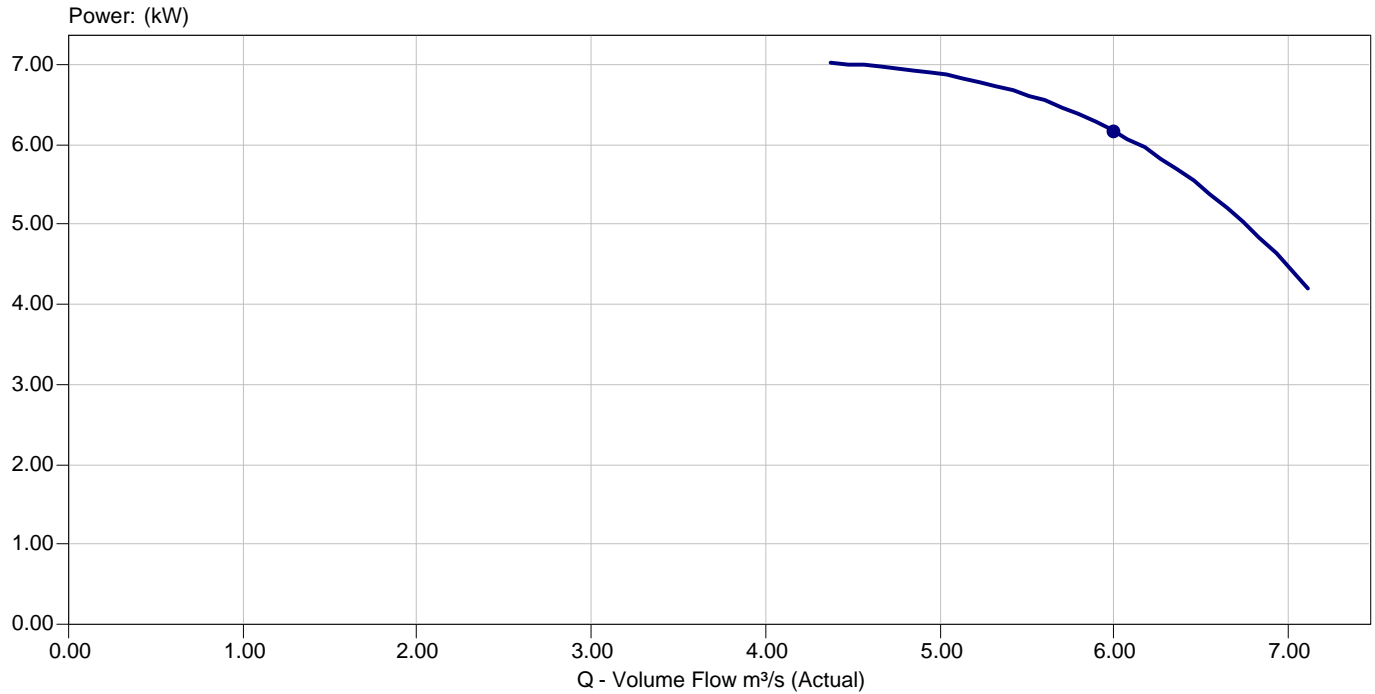



Quotation Number :
Project Name :
Item Reference :

Fan Code : 63-3MaXfan2/25/4/9/40/32
Customer :
Date : Thursday, November 21, 2024

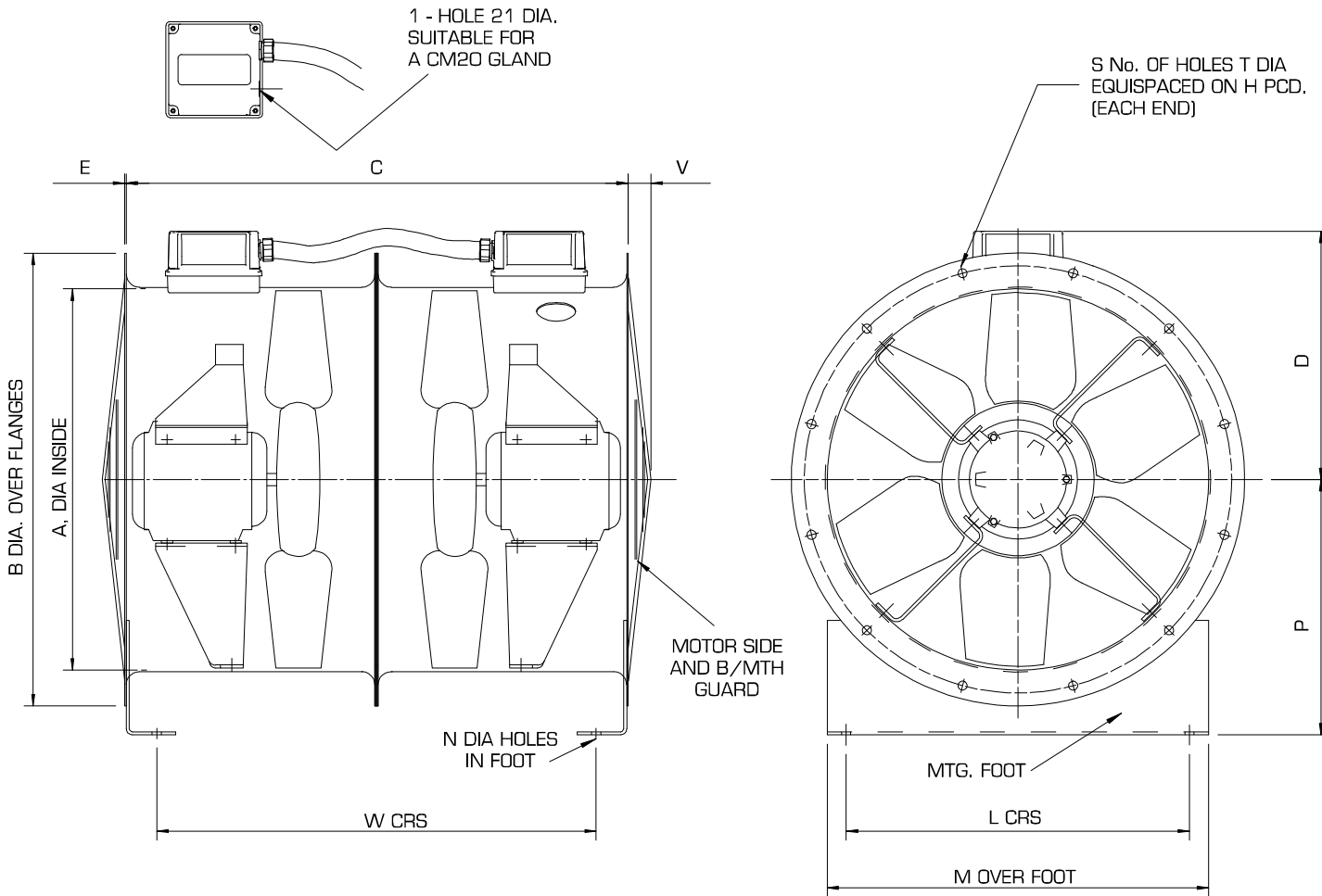

A	630
B	724
C	1040
D	403
E	3
H	690
L	580
M	630
N	10
P	400
S	12
T	12
V	50
W	954
Weight (kg)	184

Notes : Dimensions shown in mm / Weight in kg

Reference : Catalogue drawing

This drawing shows dimensions that should be used as a guide only and are subject to change. Certified drawings are available on request.